

**City of Urbandale  
Supplemental Specifications  
To Iowa Statewide Urban Design and Specifications  
Standard Specifications for Public Improvements – 2021 Edition  
January 2021**

Division	Section	Page/ Figure	Description of Change
1	1040 1.09	4	Delete all of 1.09, A & B
1	1040 1.10	5	1.10,A Add “6. Under no circumstances will payment for down time be made by the City of Urbandale as project field issues are being resolved. The City of Urbandale will take all necessary action to resolve issues in a timely manner.”
1	1040 1.10	5 & 6	<p>Delete all of 1.10, D, E, F, and G</p> <p>Insert 1.10, D “Arbitration Procedures”</p> <ol style="list-style-type: none"> <li>1. Contractor shall not cause a delay of work during arbitration proceedings except by agreement with Owner.</li> <li>2. Unless otherwise provided by controlling statutes parties may agree upon one arbitrator; otherwise there shall be three, one named by each party to this contract and a third chosen by two arbitrators so selected. If two arbitrators fail to select a third within fifteen (15) days then a third shall be chosen by any District Judge, to whom application in writing is made, of Judicial District in which work is to be performed. Should party demanding arbitration fail to name an arbitrator within ten (10) days of the demand, the right to arbitration shall lapse. Should other party fail to choose an arbitrator within said ten (10) days the party seeking arbitration shall make application in writing to any District Judge of the Judicial District in which the work is to be performed for appointment of a second arbitrator. If two arbitrators so chosen shall fail to select a third within fifteen (15) days then upon application of either of them to any District Judge of the Judicial District in which work is to be performed said third arbitrator shall be designated by said Judge.</li> <li>3. Should either party refuse or neglect to supply arbitrators with any papers or information demanded in writing, the arbitrators are empowered by both parties ex parte.</li> <li>4. Arbitrators shall be authorized to award to party whose contention is sustained such sums as they shall deem property for time, expense and trouble incident to appeal and, if appeal was taken without reasonable cause, damages for delay. Arbitrators shall fix their own compensation, unless otherwise provided by agreement, and shall assess costs and charges of arbitrator upon either or both parties.</li> <li>5. Award of arbitrators shall be in writing and it shall not be open to objection on account of form of proceeding or award, unless otherwise provided by controlling statutes.</li> </ol>

Division	Section	Page/ Figure	Description of Change
1	1040 1.11	6	1.11 Insert "Under no circumstances will payment for down time be made by the City of Urbandale as project field issues are being resolved. The City of Urbandale will take all necessary action to resolve issues in a timely manner."
1	1070 2.02	7	2.02,E,6 Insert "The Jurisdiction's Safety Plan is available upon request for the Engineer. The jurisdiction will make available a copy of the Jurisdiction's Safety Plan to the Contractor when the contract is awarded. Said Safety Plan is for the Contractor's information only and it is the Contractor's sole responsibility to provide, or make available this safety information to all its Subcontractors."
1	1090 1.08	3	1.08,E Insert "Lien Waivers from all subcontractors shall be submitted by the Contractor before final acceptance by the Jurisdiction."
4	4020 3.06	8	3.06,B Replace first sentence with "Install apron footings on all concrete aprons. Install apron footings on other aprons where specified."
4	4030 3.02	5	3.02,B, Replace first sentence with "Install apron footings on all concrete aprons. Install apron footings on other aprons where specified."
4	4060 3.02	3	3.02,A,5 Insert "Video inspection to be performed after backfill over sanitary sewer has been in place a minimum of 30 days and prior to paving operations unless approved earlier by Engineer. Pavement placement prior to 30 days after backfill at contractor's risk."
5	5010 5020 5030 All	All	Delete entire Division and insert "Water main standards in the City of Urbandale shall meet the requirements of the Urbandale Water Utility Standard Specifications for Water Mains and Appurtenances, dated February 28, 2017."
6	6010 2.02	4	2.02,A Insert "Precast Requirements: the City of Urbandale will allow precast intakes and rectangular storm sewer manholes when all of the following conditions are met:  1. Construction is new and not a replacement of an existing structure. 2. Pipe diameter is 24" or less. 3. Minimum 75° separation is provided between pipes, and between pipe and face of structure. 4. Precast portion is a dead end structure, cross-run structure or directional change structure. 5. Pipe opening does not encroach within 2 inches of corner post."
6	6010 2.09	6	Delete 2.09,A,1. Only High Density Polyethylene Adjustment Rings or Expanded Polypropylene Adjustment Rings are allowed.
6	6010 2.10	7	2.10,D,2,b replace with "Casting shall include stamped message "DUMP NO WASTE, DRAINS TO STREAM" or Engineer approved equivalent."
6	6010 2.12	8	2.12,C Insert "Provide invert and 2' stub for future sewer extension."

Division	Section	Page/ Figure	Description of Change
6	6010 2.16	9	2.16,A Insert "Internal drop connection not allowed except with prior approval of Engineer."
6	6010 3.01	12	3.01,H Replace with "Install manhole eccentric cone or flat top section or install intake top, embedded in grout."
6	6010 3.05	17	3.05,D,1 Insert "Use only when specified." 3.05,D,2a Replace with "a. Core drill new openings in existing manholes or intakes for all pipes unless otherwise specified in the contract documents. Notify the Jurisdiction for inspection prior to placing backfill material."
6	6010 3.06	17	3.06,A, Insert "Internal drop connection not allowed except with prior approval of Engineer."
6	6010	6010.308	Insert "Internal drop connection requires prior approval of Engineer."
6	6010	6010.514	Replace 'ED' Joint with a 'RD' Joint.
7	7010 2.02	7	2.02,D Insert "All paving to be C4 mix."
7	7010 3.07	24 & 25	3.07,C.1 Replace first sentence with "The Contractor will check PCC pavement surfaces with a 10 foot straightedge placed parallel to the centerline in the presence of City Staff." 3.07,C.2.d Insert "Pavements 8" and greater in thickness will be evaluated for smoothness." 3.07,D,1. Insert new sentence "Jurisdiction reserves the right to waive cores."
7	7010	7010.901	Detail 7010.901 Gutter line jointing is the City of Urbandale's preferred jointing. Insert General Note #6 – "No dowels in the curb and gutter section of pavement for 26' B/B."
7	7020 1.02	1	1.02,C Insert "City of Urbandale shall comply with section 7020, 3.06 for HMA Quality Control. QMA shall be waived." 1.02,D Insert "Use of Hot Mix Asphalt Pavement for streets and related work will only be permitted with prior Jurisdictional Engineer approval."
7	7020 3.05	9	3.05,A Replace first sentence with "The Contractor will check PCC pavement surfaces with a 10 foot straightedge placed parallel to the centerline in the presence of City Staff."
7	7030 2.07	6	2.07 Insert "Detectable warning panels to be Armor Tile, ADA Solutions or approved equal, brick red in color, cast-in-place."
7	7030 3.02	7	Delete 3.02,A,1 and insert 3.02,A,1 "Subgrade Preparation: Subgrade to meet requirements of 3.02,B, Sidewalk and Driveways."
7	7030	7030.101	Replace with Urbandale Figure 7030.101
7	7030	7030.102	Replace with Urbandale Figure 7030.102

<b>Division</b>	<b>Section</b>	<b>Page/ Figure</b>	<b>Description of Change</b>
7	7030	7030.204	Replace with Urbandale Figure 7030.204
9	9070 1.03	1	1.03,D Insert "D. Submit a minimum of three color choices, not to include gray, from the Manufacturer's standard colors for approval."
9	9070 2.01	3	2.01,A,1 Insert "e. block weight to be minimum 100 pounds per block."
9	9071 2.01	1	1.03,F Insert "F. Submit a minimum of three color choices, not to include gray, from the Manufacturer's standard colors for approval."

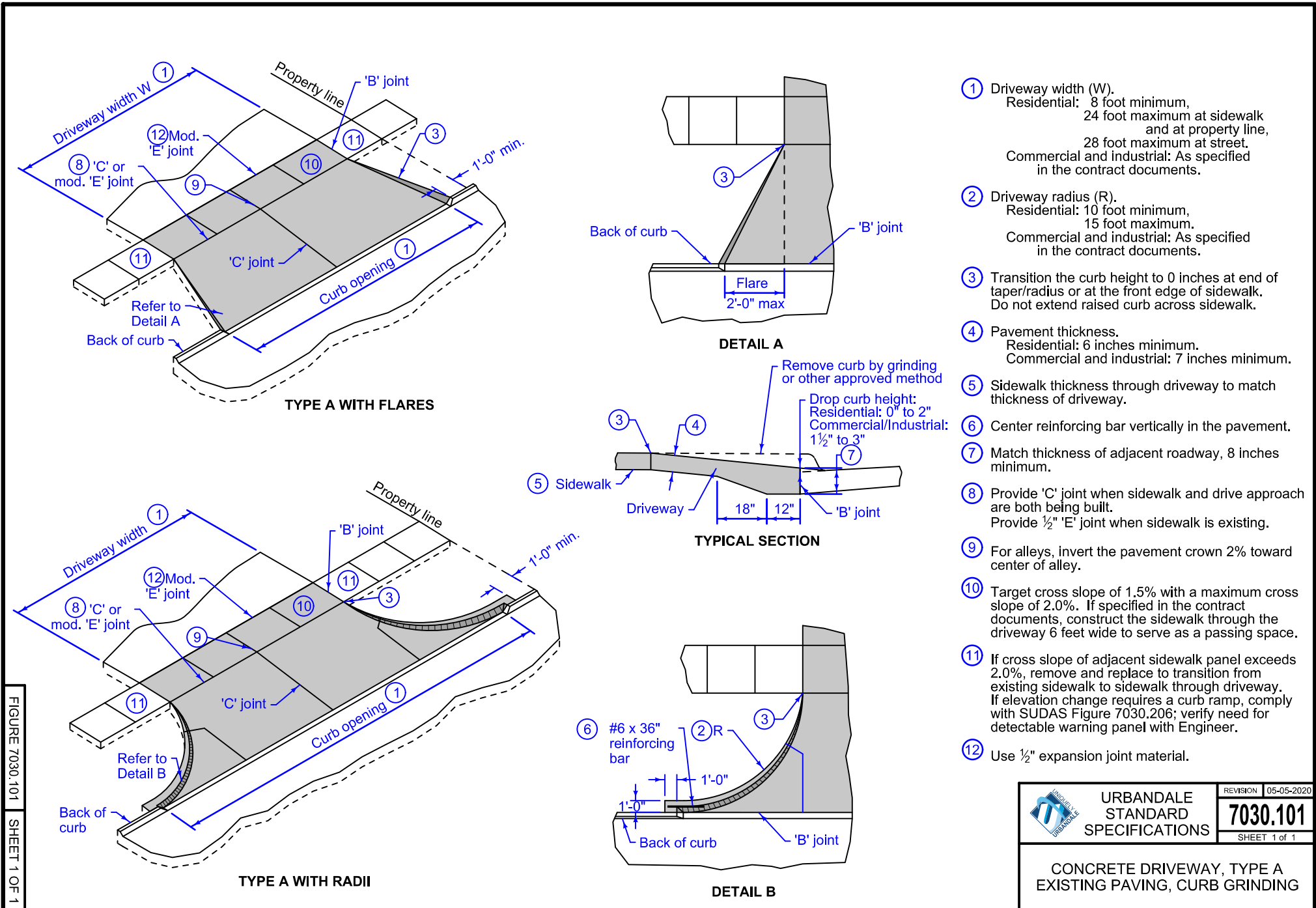

- ① Driveway width (W).  
Residential: 8 foot minimum, 24 foot maximum at sidewalk and at property line, 28 foot maximum at street.  
Commercial and industrial: As specified in the contract documents.
- ② Driveway radius (R).  
Residential: 10 foot minimum, 15 foot maximum.  
Commercial and industrial: As specified in the contract documents.
- ③ Transition the curb height to 0 inches at end of taper/radius or at the front edge of sidewalk. Do not extend raised curb across sidewalk.
- ④ Pavement thickness.  
Residential: 6 inches minimum.  
Commercial and industrial: 7 inches minimum.
- ⑤ Sidewalk thickness through driveway to match thickness of driveway.
- ⑥ Center reinforcing bar vertically in the pavement.
- ⑦ Match thickness of adjacent roadway, 8 inches minimum.
- ⑧ Provide 'C' joint when sidewalk and drive approach are both being built. Provide ½" 'E' joint when sidewalk is existing.
- ⑨ For alleys, invert the pavement crown 2% toward center of alley.
- ⑩ Target cross slope of 1.5% with a maximum cross slope of 2.0%. If specified in the contract documents, construct the sidewalk through the driveway 6 feet wide to serve as a passing space.
- ⑪ If cross slope of adjacent sidewalk panel exceeds 2.0%, remove and replace to transition from existing sidewalk to sidewalk through driveway. If elevation change requires a curb ramp, comply with SUDAS Figure 7030.206; verify need for detectable warning panel with Engineer.
- ⑫ Use ½" expansion joint material.

	URBANDALE STANDARD SPECIFICATIONS	REVISION 05-05-2020
	7030.101	SHEET 1 of 1
CONCRETE DRIVEWAY, TYPE A EXISTING PAVING, CURB GRINDING		

THIS DETAIL ONLY TO BE USED WITH PRIOR APPROVAL FROM CITY OF URBANDALE ENGINEERING DEPARTMENT.

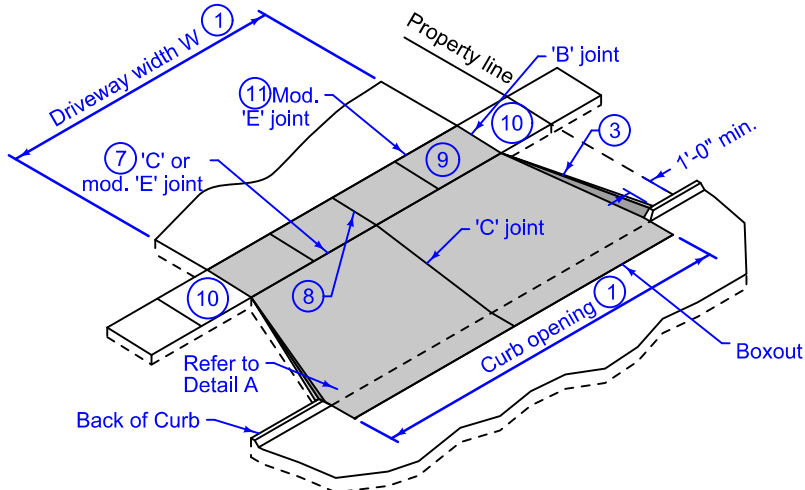

**TYPE B WITH FLARES**

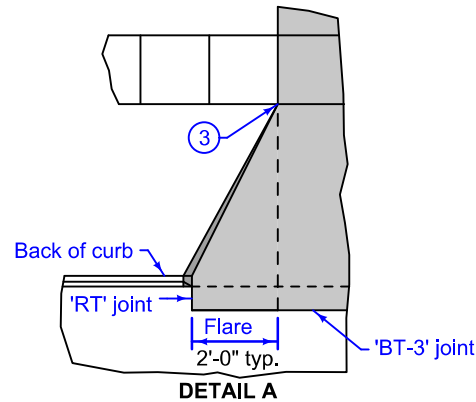

**DETAIL A**

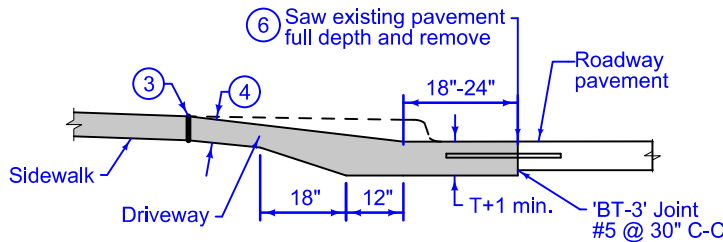

**SECTION A-A**

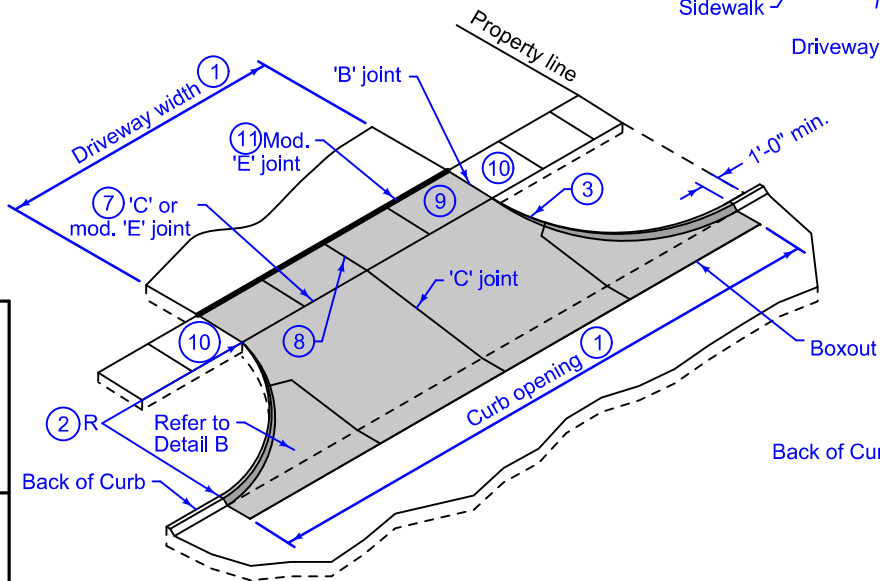

**TYPE B WITH RADII**

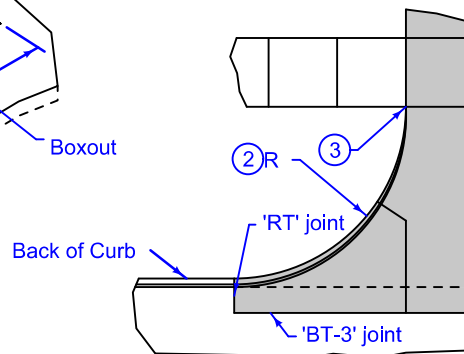



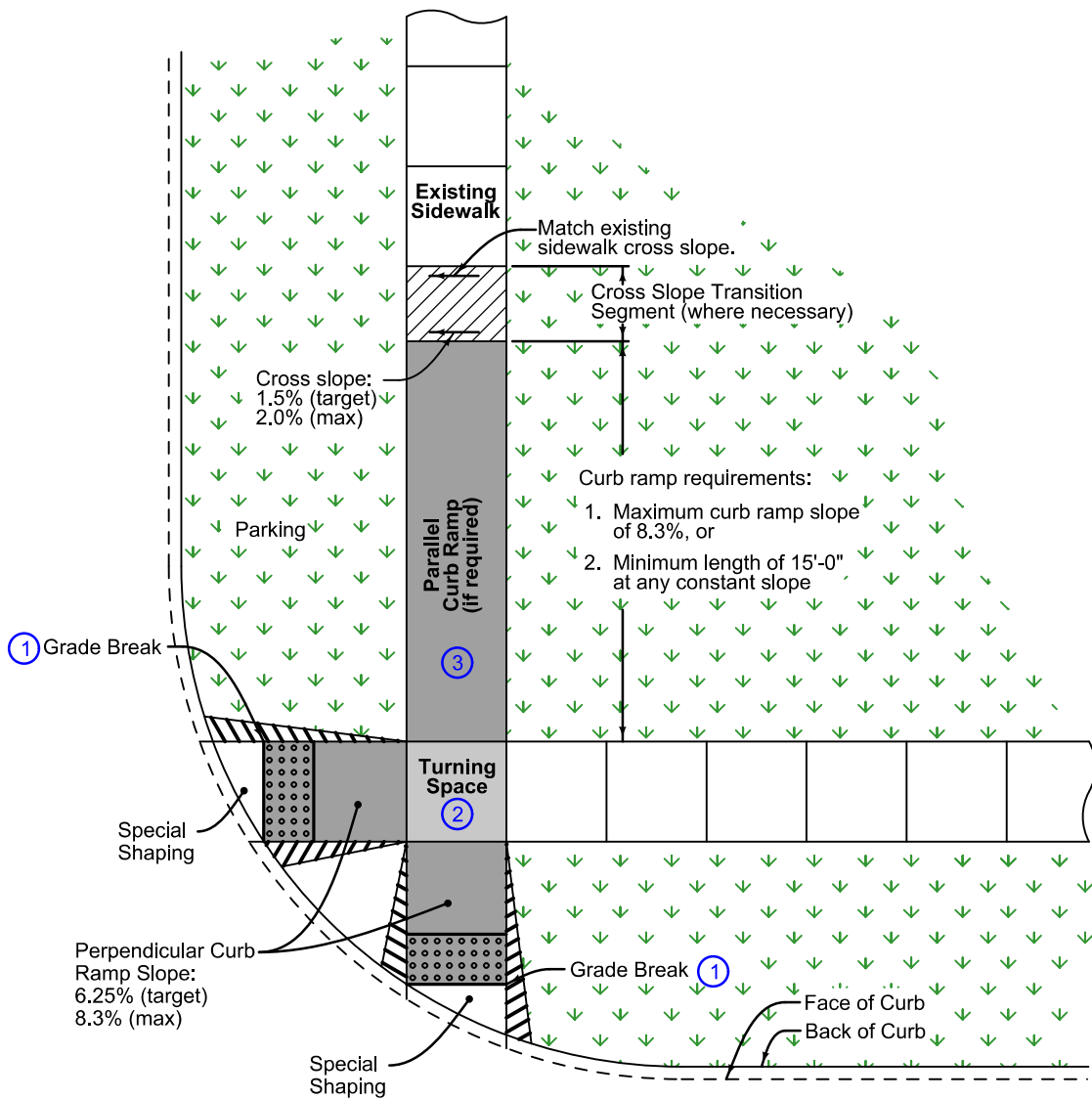

**DETAIL B**

- 1 Driveway width (W).  
Residential: 8 foot minimum, 24 foot maximum at sidewalk and at property line, 28 foot maximum at street.  
Commercial and industrial: As specified in the contract documents.
- 2 Driveway radius (R).  
Residential: 10 foot minimum, 15 foot maximum.  
Commercial and industrial: As specified in the contract documents.
- 3 Transition the curb height to 0 inches at end of taper/radius or at the front edge of sidewalk. Do not extend raised curb cross sidewalk.
- 4 Pavement thickness.  
Residential: 6 inches minimum.  
Commercial and industrial: 7 inches minimum.
- 5 Sidewalk thickness through driveway to match thickness of driveway.
- 6 If longitudinal joint is located 48 inches or less from the back of curb, extend boxout to joint line. Full depth saw cut is still required.
- 7 Provide 'C' joint when sidewalk and drive approach are both being built. Provide 1/2" 'E' joint when sidewalk is existing.
- 8 For alleys, invert the pavement crown 2% toward the center of the alley.
- 9 Target cross slope of 1.5% with a maximum cross slope of 2.0%. If specified in the contract documents, construct the sidewalk through the driveway 5 feet wide to serve as a passing space.
- 10 If cross slope of adjacent sidewalk panel exceeds 2.0%, remove and replace to transition from existing sidewalk to sidewalk through driveway. If elevation change requires a curb ramp, comply with SUDAS Figure 7030.205; verify need for detectable warning panel with Engineer.
- 11 Use 1/2" expansion joint material.



- ① Match pedestrian street crossing slope, or flatter.
- ② Minimum 5 feet by 5 feet, unless approved by Engineer. Target slope = 1.5%; maximum slope = 2.0% perpendicular to adjoining sidewalks and curb ramps.
- ③ All Urbandale Sidewalks to be 5 feet wide, unless approved by Engineer.
- ④ Detectable warning panels to be Armor Tile, ADA Solutions, or approved equal, brick red in color. Brick pavers will not be allowed.

Key

-  Curb Ramp
-  Turning Space
-  Detectable Warning ④
-  Grass

	URBANDALE STANDARD SPECIFICATIONS	REVISION 04-29-16
	<b>7030.204</b>	SHEET 1 of 1
GENERAL FEATURES OF AN ACCESSIBLE SIDEWALK		